

Trolleys Series H

Load capacity up to 160 metric tons

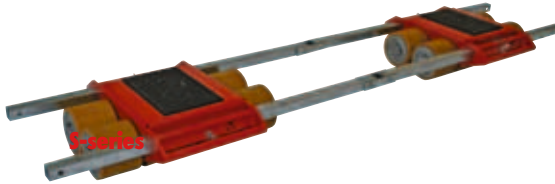

JL 80 H



JFB 80 H

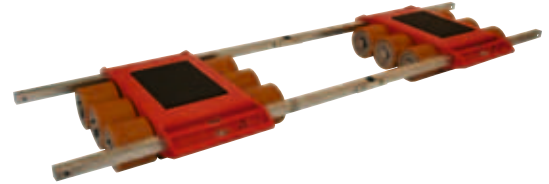

JFB 120 H

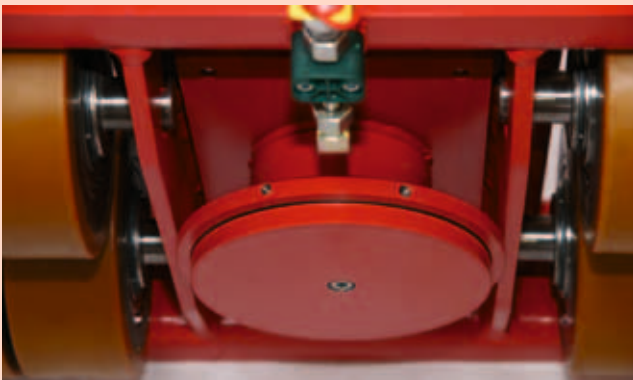

Turning assistance for H series trolleys available on request

Advantages in detail

- Outfitted with highest quality rollers as standard.
- Unrivalled: Small and lightweight trolleys at super high capacity.
- Reduced weight through advanced construction of frames.
- All transport trolleys are ready for use: The steerable transport trolley is fitted with a ball bearing supported turntable and a handlebar (as shown in picture). The adjustable-width transport trolley consists of two transport units and connecting rods.

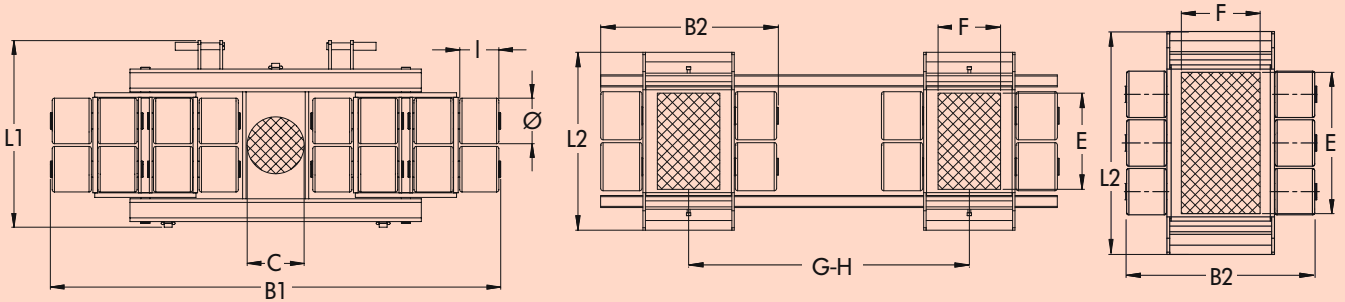

Type	Sketch		JL 80 H	JFB 80 H	JFB 120 H
Load capacity		kg / lbs	80 000 / 176 000	80 000 / 176 000	120 000 / 265 000
Number of castors		pcs	16	16	24
Castors dimensions	Ø x l	mm / in	200 x 170 / 7.9 x 6.7"	200 x 170 / 7.9 x 6.7"	200 x 170 / 7.9 x 6.7"
Fitting height		mm / in	240 / 9.4"	240 / 9.4"	240 / 9.4"
Supporting surface per cassette	E x F	mm / in		400 x 260 / 15.7 x 10.2"	440 x 300 / 17.3 x 11.8"
Cassette dimensions	L2 x B2	mm / in		750 x 820 / 29.5 x 32.2"	960 x 830 / 37.7 x 32.6"
Connecting rod with joint	Length	mm / in		2 x 3 000 / 118"	2 x 3 000 / 118"
Cassettes adjustable from - to	G - H	mm / in		1 630 - 3 380 / 64.1-132.9"	1 630 - 3 380 / 64.1-132.9"
Supporting surface of turntable	Ø C	mm / in	250 / 9.8"		
Dimensions	L1 x B1	mm / in	820 x 1 900 / 32.2 x 74.7"		
Handlebar with pulling eye	Length	mm / in	1 590 / 62.6"		
Weight JUWAtan plus		kg / lbs	723 / 1 594	565 / 1 246	815 / 1 797
Order-no. with JUWAtan			09 800 200-H	10 800 200-H	10 912 200-H